



US 20150357384A1

(19) **United States**

(12) **Patent Application Publication**
LI et al.

(10) **Pub. No.: US 2015/0357384 A1**
(43) **Pub. Date: Dec. 10, 2015**

(54) **OLED DISPLAY PANEL AND METHOD FOR MANUFACTURING THE SAME**

Publication Classification

(71) Applicant: **BOE TECHNOLOGY GROUP CO., LTD.**, Beijing (CN)

(51) **Int. Cl.**
H01L 27/32 (2006.01)
H01L 51/56 (2006.01)
H01L 51/52 (2006.01)

(72) Inventors: **Yunfei LI**, Beijing (CN); **Kazuyoshi NAGAYAMA**, Beijing (CN)

(52) **U.S. Cl.**
CPC *H01L 27/3216* (2013.01); *H01L 27/322* (2013.01); *H01L 51/5231* (2013.01); *H01L 27/3258* (2013.01); *H01L 51/56* (2013.01); *H01L 2227/323* (2013.01)

(73) Assignee: **BOE TECHNOLOGY GROUP CO., LTD.**, Beijing (CN)

(57) **ABSTRACT**

(21) Appl. No.: **14/416,257**

Provided are OLED display panel and method for manufacturing the same. The OLED display panel includes a plurality of pixel units, each of the plurality of pixel units includes a light emitting region and a light transmitting region, the light emitting region is provided with a white organic light emitting device and a color filter; the light transmitting region is not provided with the color filter. According to embodiments of the present disclosure, a light transmitting region is particularly added on the color filter, so that the transmittance can be increased, so as to obtain a better transparent display effect without an extra process, which can be achieved only by appropriately adjusting design.

(22) PCT Filed: **Apr. 17, 2014**

(86) PCT No.: **PCT/CN2014/075546**

§ 371 (c)(1),
(2) Date: **Jan. 21, 2015**

(30) **Foreign Application Priority Data**

Dec. 27, 2013 (CN) 201310741370.6

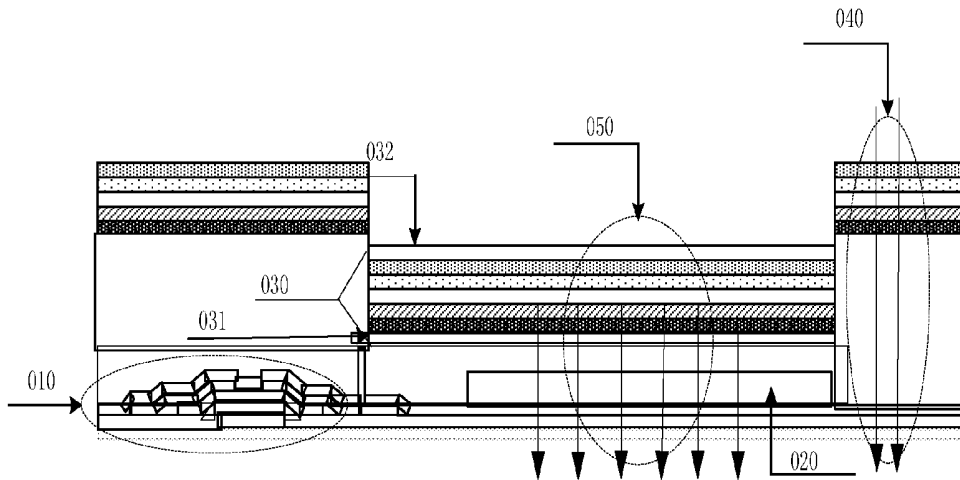

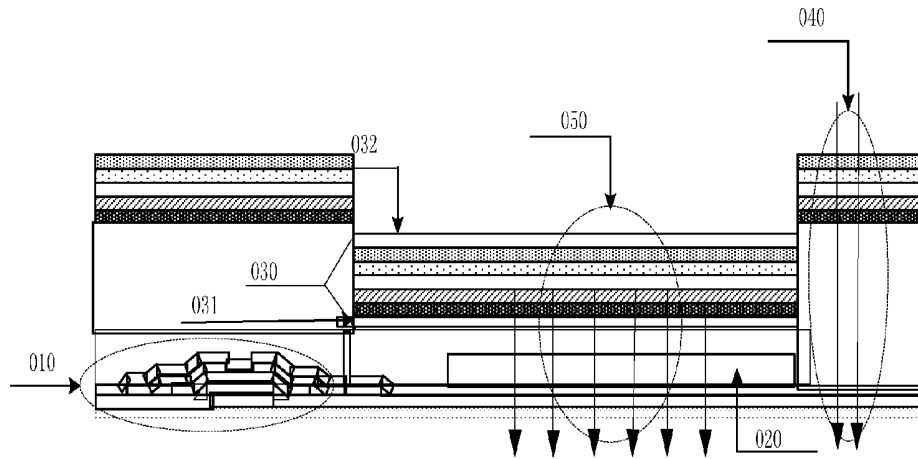

Fig. 1A

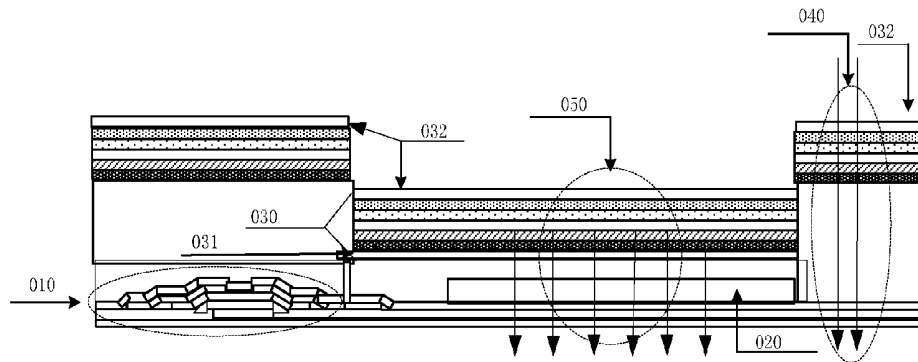

Fig. 1B

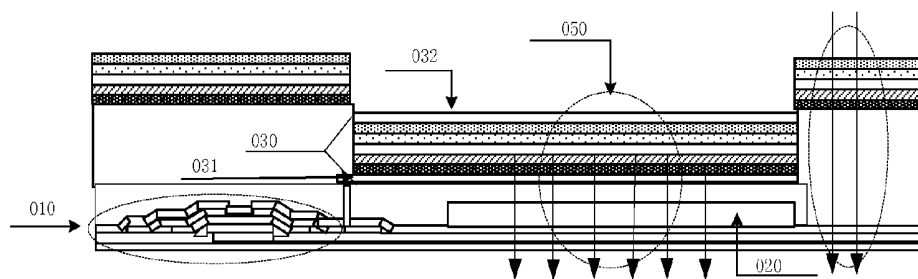

Fig. 1C

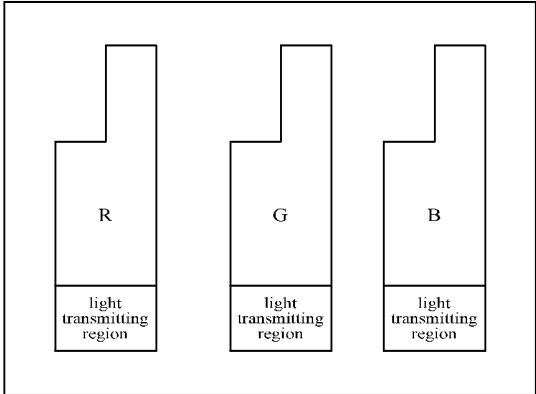

Fig. 2A

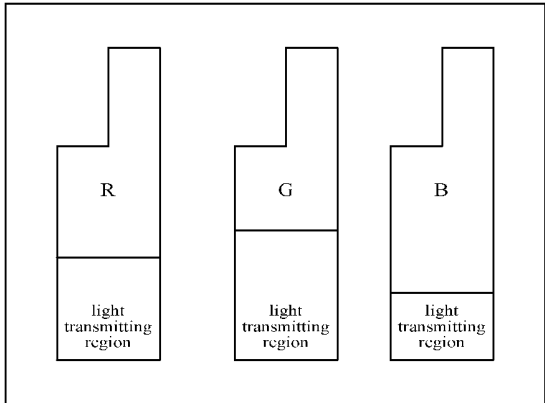

Fig. 2B

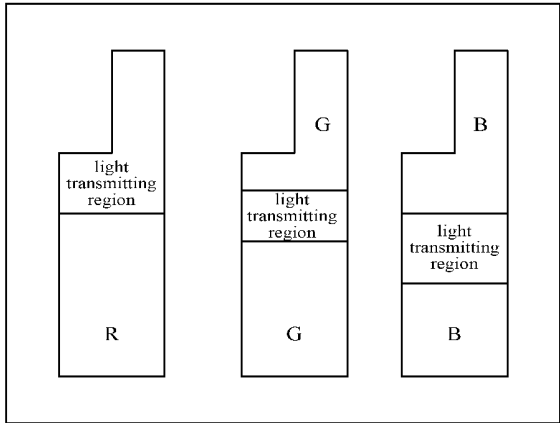

Fig. 2C

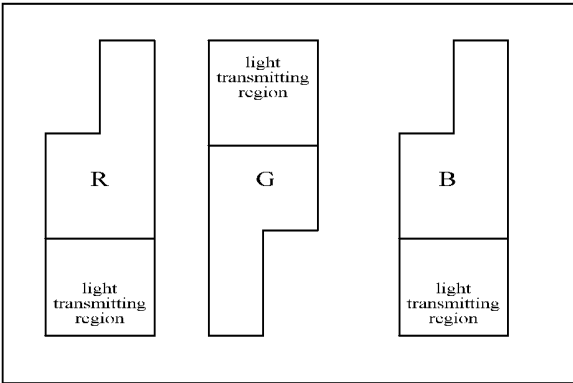

Fig. 2D

OLED DISPLAY PANEL AND METHOD FOR MANUFACTURING THE SAME

CROSS-REFERENCE TO RELATED APPLICATION

[0001] This application is the U.S. national phase of PCT Application No. PCT/CN2014/075546 filed on Apr. 17, 2014, which claims priority to Chinese Patent Application No. 201310741370.6 filed on Dec. 27, 2013, the disclosure of which is incorporated in its entirety by reference herein.

TECHNICAL FIELD

[0002] The present disclosure relates to the field of display technology, in particular to an organic light emitting diode display panel and a method for manufacturing the same.

BACKGROUND

[0003] Transparent display is a relative hot technology trend in recent year, both reflective type Liquid Crystal Display (LCD) and Organic Light-Emitting Diode (OLED) can achieve transparent display, in which OLED has a better transparent display effect.

[0004] The existing OLED display panel uses an OLED array substrate with a structure formed by combining a white OLED with a color filter, having a low transmittance and a poor transparent display effect.

SUMMARY

[0005] Embodiments of the present disclosure provides an OLED display panel and a method for manufacturing the same, to solve the problem of poor transparent display effect of OLED display panels in prior art.

[0006] In order to achieve the above objective, the present disclosure provides an organic light emitting diode (OLED) display panel, including a plurality of pixel units, each of the plurality of pixel units includes a light emitting region and a light transmitting region, the light emitting region is provided with a white organic light emitting device and a color filter;

[0007] the light transmitting region is not provided with the color filter.

[0008] Alternatively, a cathode of the white organic light emitting device is made of an opaque material or a semi-opaque material, the light transmitting region is not provided with the cathode of the white organic light emitting device.

[0009] Alternatively, the light transmitting region is not provided with an anode and/or a light emitting function film of the white organic light emitting device.

[0010] Alternatively, the light transmitting region is arranged on a region of the pixel unit where a thin film transistor device and a metal wire are not provided.

[0011] Alternatively, the respective light transmitting regions in the plurality of pixel units have a same position and a same size.

[0012] Alternatively, the respective light transmitting regions in the plurality of pixel units have a different position and a different size.

[0013] Alternatively, the plurality of pixel units include a green pixel unit, a red pixel unit and a blue pixel unit, the light transmitting region of the green pixel unit has an area of T_G , the light transmitting region of the red pixel unit has an area of T_R , the light transmitting region of the blue pixel unit has an area of T_B , wherein $T_G > T_R > T_B$.

[0014] Alternatively, the OLED display panel includes an array substrate;

[0015] the array substrate includes a base substrate, a thin film transistor device and the color filter;

[0016] the thin film transistor device and the color filter are arranged on the base substrate;

[0017] an overcoat is arranged on the thin film transistor device and the color filter, the white organic light emitting device is arranged on the overcoat.

[0018] Alternatively, the OLED display panel includes an array substrate and a packaging substrate,

[0019] the array substrate includes a base substrate, a thin film transistor device and the white organic light emitting device;

[0020] the thin film transistor device and the white organic light emitting device are arranged on the base substrate;

[0021] the color filter is arranged on the packaging substrate at a position corresponding to the white organic light emitting device.

[0022] Embodiments of the present disclosure further provide a method for manufacturing an organic light emitting diode (OLED) display panel, which is used for manufacturing the above OLED display panel, including a step of:

[0023] forming the color filter and the white organic light emitting device in the light emitting region in each of the plurality of pixel units included in the OLED display panel, the light transmitting region in each of the plurality of pixel units is not provided with the color filter.

[0024] Alternatively, the method for manufacturing the OLED display panel according to embodiments of the present disclosure further includes a step of:

[0025] forming a cathode of the white organic light emitting device in the light emitting region in each of the plurality of pixel units, wherein the light transmitting region in each of the plurality of pixel units is not provided with the cathode.

[0026] Alternatively, the method for manufacturing the OLED display panel according to embodiments of the present disclosure further includes a step of:

[0027] forming an anode, a light emitting function film and a cathode of the white organic light emitting device in the light emitting region in each of the plurality of pixel units, wherein the light transmitting region in each of the plurality of pixel units is not provided with the anode, the light emitting function film and a cathode.

[0028] Alternatively, the method for manufacturing the OLED display panel according to embodiments of the present disclosure further includes a step of:

[0029] forming an anode and a light emitting function film of the white organic light emitting device in the light emitting region in each of the plurality of pixel units, wherein the light transmitting region in each of the plurality of pixel units is not provided with the anode and/or the light emitting function film.

[0030] Comparing with the prior art, the OLED display panel and the method for manufacturing the same according to embodiments of the present disclosure, through not providing the color filter in the light transmitting region in each of the plurality of the pixel units, can increase the transmittance, so as to obtain a better transparent display effect without an extra process, which can be achieved only by appropriately adjusting design.

BRIEF DESCRIPTION OF THE DRAWINGS

[0031] FIG. 1A is a structure schematic view of an OLED display panel according to an embodiment of the present disclosure;

[0032] FIG. 1B is a structure schematic view of an OLED display panel according to another embodiment of the present disclosure;

[0033] FIG. 1C is a structure schematic view of an OLED display panel according to still another embodiment of the present disclosure

[0034] FIG. 2A, FIG. 2B, FIG. 2C, FIG. 2D are a schematic view of a light transmitting region and a light emitting region included in an OLED display panel according to embodiments of the present disclosure respectively.

FIGURE REFERENCE

[0035] **010**: thin film transistor, **020**: color filter (CF),

[0036] **030**: white organic light-emitting device, **031**: anode of white organic light emitting device, **031**: cathode of white organic light emitting device,

[0037] **040**: light transmitting region, **050**: light emitting region.

DETAILED DESCRIPTION

[0038] The OLED display panel according to embodiments of the present disclosure includes a plurality of pixel units, each of the plurality of pixel units includes a light emitting region and a light transmitting region, the light emitting region is provided with a white organic light emitting device and a color filter;

[0039] and wherein the light transmitting region is not provided with the color filter.

[0040] The OLED display panel according to embodiments of the present disclosure, through not providing the color filter in the light transmitting region in each of the plurality of pixel units, can increase the transmittance, so as to obtain a better transparent display effect without an extra process, which can be achieved only by appropriately adjusting design.

[0041] When being specifically implemented, a position, a size and an arrangement of the light transmitting region can be determined in line with specific design requirements, without special requirements. The pixels arrangement in the pixel unit may be in a strip way, or may be in a triangle way, or in other ways.

[0042] In an example, when a cathode of the white organic light emitting device is made of an opaque material or a semiopaque material, and the light transmitting region is not provided with the cathode of the white organic light emitting device, then the transmittance is further increased.

[0043] As shown in FIG. 1A, when the cathode of the white organic light emitting device is made of an opaque material, the light transmitting region is not provided with the color filter and the cathode of the white organic light emitting device, so as to guarantee the transmittance of the light in the light transmitting region.

[0044] As shown in FIG. 1B, when the cathode of the white organic light emitting device is made of a transparent material or a semiopaque material, the light transmitting region is not provided with the color filter, while the light transmitting region may be provided with the cathode of the white organic light emitting device. The reason for such arrangement is that: a Fine Metal Mask (FMM) is necessary to block the light

transmitting region if the light transmitting region is not provided with the cathode of the white organic light emitting device, but the FMM has a relative higher cost, thus considering the cost problem, when the used material for the cathode of the white organic light emitting device has a relative higher transparency, the cathode of the white organic light emitting device may be arranged in the light transmitting region, by which both the transmittance and the cost can be taken into account.

[0045] As shown in FIG. 1C, when the cathode of the white organic light emitting device is made of a transparent material or a semiopaque material, the light transmitting region may also not be provided with the color filter and the cathode of the white organic light emitting device, so as to guarantee the transmittance of the light in the light transmitting region.

[0046] In an example, the light transmitting region is not provided with an anode and/or a light emitting function film of the white organic light emitting device, so as to further increase the transmittance.

[0047] For example, the light emitting function film of the white organic light emitting device may include a Hole Injection Layer (HIL), a Hole Transport Layer (HTL), an Emitting Layer (EML), an Electron Transport Layer (ETL), and an Electron Injection Layer (EIL).

[0048] Alternatively, the light transmitting region is arranged on a region of the pixel unit where a thin film transistor device and a metal wire are not provided, so as to avoid influencing the formation of the thin film transistor device and the metal wire by arranging the light transmitting region. The thin film transistor device and the metal wire may influence light transmission, thus the light transmitting region is arranged on a region where a thin film transistor device and a metal wire are not provided.

[0049] Alternatively, the respective light transmitting region may have a same position and a same size in each of the plurality of pixel units, or may have a different position and/or a different size in each of the plurality of pixel units.

[0050] In details, as shown in FIG. 2A, the plurality of pixel units include a red pixel unit R, a green pixel unit G, and a blue pixel unit B, a light transmitting region of the red pixel unit R locates at bottom of the red pixel unit R, a light transmitting region of the green pixel unit G locates at bottom of the green pixel unit G, a light transmitting region of the blue pixel unit B locates at bottom of the blue pixel unit B; the light transmitting region of the red pixel unit has an area of T_R , the light transmitting region of the green pixel unit has an area of T_G , the light transmitting region of the blue pixel unit has an area of T_B , $T_G = T_R = T_B$. In FIG. 2A, the light transmitting region of the red pixel unit R, the light transmitting region of the green pixel unit G and the light transmitting region of the blue pixel unit B have a same position and a same size.

[0051] As shown in FIG. 2B, the plurality of pixel units include a red pixel unit R, a green pixel unit G, and a blue pixel unit B, a light transmitting region of the red pixel unit R locates at bottom of the red pixel unit R, a light transmitting region of the green pixel unit G locates at bottom of the green pixel unit G, a light transmitting region of the blue pixel unit B locates at bottom of the blue pixel unit B; the light transmitting region of the red pixel unit has an area of T_R , the light transmitting region of the green pixel unit has an area of T_G , the light transmitting region of the blue pixel unit has an area of T_B , $T_G > T_R > T_B$. As in most existing OLED display panels, the green pixel unit G has the most intensive light intensity, the red pixel unit R has a less intensive light intensity than the

green pixel unit G, and the blue pixel unit B has the least intensive light intensity, thus in FIG. 2B, the area of the light transmitting region of the green pixel unit G is set as the largest one, the area of the light transmitting region of the red pixel unit R is set as a smaller one comparing with that of the green pixel unit G, and the area of the light transmitting region of the blue pixel unit B is set as the smallest one.

[0052] As shown in FIG. 2C, the plurality of pixel units include a red pixel unit R, a green pixel unit G, and a blue pixel unit B, a light transmitting region of the red pixel unit R locates at top of the red pixel unit R, a light transmitting region of the green pixel unit G locates in the middle of the green pixel unit G, a light transmitting region of the blue pixel unit B locates in the middle of the blue pixel unit B; the light transmitting region of the red pixel unit has an area of T_R , the light transmitting region of the green pixel unit has an area of T_G , the light transmitting region of the blue pixel unit has an area of T_B , $T_R > T_B > T_G$.

[0053] As shown in FIG. 2D, the plurality of pixel units include a red pixel unit R, a green pixel unit G, and a blue pixel unit B, a light transmitting region of the red pixel unit R locates at bottom of the red pixel unit R, a light transmitting region of the green pixel unit G locates at top of the green pixel unit G, a light transmitting region of the blue pixel unit B locates at bottom of the blue pixel unit B; the light transmitting region of the red pixel unit has an area of T_R , the light transmitting region of the green pixel unit has an area of T_G , the light transmitting region of the blue pixel unit has an area of T_B , $T_R = T_B = T_G$.

[0054] When the OLED display panel is a bottom emitting OLED display panel, the OLED display panel includes an array substrate; the array substrate includes a base substrate, a thin film transistor device and the color filter;

[0055] the thin film transistor device and the color filter are arranged on the base substrate;

[0056] an overcoat is arranged on the thin film transistor device and the color filter, the white organic light emitting device is arranged on the overcoat.

[0057] When manufacturing a bottom emitting OLED display panel, the manufacturing process includes: on the array substrate which is provided with a thin film transistor, manufacturing a Black Matrix (BM) and a color filter, and then manufacturing a white organic light emitting device.

[0058] When the OLED display panel is a top emitting OLED display panel, the OLED display panel includes an array substrate and a packaging substrate;

[0059] the array substrate includes a base substrate, a thin film transistor device and the white organic light emitting device;

[0060] the thin film transistor device and the white organic light emitting device are arranged on the base substrate;

[0061] the color filter is arranged on the packaging substrate at a position corresponding to the white organic light emitting device.

[0062] When manufacturing a top emitting OLED display panel, the manufacturing process includes: on the array substrate which is provided with a thin film transistor, manufacturing a white organic light emitting device, and then manufacturing a color filter. Comparing with manufacturing the bottom emitting OLED display panel, the order of manufacturing the color filter and the white organic light emitting device is adjusted, so as to meet the requirements for the top emitting OLED display panel.

[0063] The method for manufacturing the OLED display panel according to embodiments of the present disclosure, which is used for manufacturing the above OLED display panel, includes a step of:

[0064] forming the color filter and the white organic light emitting device in the light emitting region in each of the plurality of pixel units included in the OLED display panel, the light transmitting region in each of the plurality of pixel units is not provided with the color filter.

[0065] The method for manufacturing the OLED display panel according to embodiments of the present disclosure, through not providing the color filter in the light transmitting region in each of the plurality of the pixel units, can increase the transmittance, so as to obtain a better transparent display effect without an extra process, which can be achieved only by appropriately adjusting design.

[0066] Alternatively, the method for manufacturing the OLED display panel according to embodiments of the present disclosure, further includes a step of:

[0067] forming a cathode of the white organic light emitting device in the light emitting region in each of the plurality of pixel units, the light transmitting region in each of the plurality of pixel units is not provided with the cathode. By including such step, the transmittance may be further increased.

[0068] Alternatively, the method for manufacturing the OLED display panel according to embodiments of the present disclosure, further includes a step of:

[0069] forming an anode and a light emitting function film of the white organic light emitting device in the light emitting region in each of the plurality of pixel units, the light transmitting region in each of the plurality of pixel units is not provided with the anode and/or the light emitting function film. By including such step, the transmittance may be further increased.

[0070] Alternatively, the method for manufacturing the OLED display panel according to embodiments of the present disclosure, further includes a step of: forming an anode, a light emitting function film and a cathode of the white organic light emitting device in the light emitting region in each of the plurality of pixel units, the light transmitting region in each of the plurality of pixel units is not provided with the anode, the light emitting function film and the cathode. By including such step, the transmittance of the light transmitting region may be further increased.

[0071] When being specifically implemented, the OLED display panel according to embodiments of the present disclosure may be various OLED display panels manufactured on the array substrate, such as an amorphous silicon thin film transistor (a-Si TFT) OLED display panel, an oxide thin film transistor (Oxide TFT) OLED display panel, a polycrystalline silicon thin film transistor (poly-Si TFT) OLED display panel.

[0072] In an embodiment of the present disclosure, the method for manufacturing the OLED display panel includes: manufacturing a thin film transistor device on an array substrate; manufacturing a color filter on the substrate provided with the thin film transistor device; manufacturing a white organic light emitting device on the substrate provided with the thin film transistor device and the color filter.

[0073] The base substrate is made of a transparent material. The transparent material, for example, may be glass, quartz, or may be a resin material with a good transparency, such as an acrylic resin, a methacrylic resin, and so on. The thin film

transistor may be a top-gate type, or may be a bottom-gate type. The present embodiment takes the bottom-gate type thin film transistor as an example for illustration. A gate electrode layer pattern including a gate electrode, a gate insulating layer, an active layer pattern, a source-drain electrode layer pattern including a source electrode and a drain electrode and a passivation layer pattern are successively formed on the base substrate, so as to form the thin film transistor.

[0074] A color filter is formed in the light emitting region in each of the plurality of the pixel units, but not formed in the light emitting region. The color filter may use an organic resin material which can be passed through red color, green color, blue color or yellow color. The color filter may be formed by using a process of exposing and developing, or may be formed by using an inkjet printing process, a heat transfer process, and other processes, as long as guarantying that the light transmitting region is not provided with the color filter, while the light emitting region is provided with the color filter. For example, a layer of red resin material may be firstly coated, then an exposing region and a non-exposing region are formed by exposure using a mask, and then after development, the red resin in the exposing region is retained, i.e., a red color filter in light emitting region of the red pixel unit is formed, and red resin layer in the non-exposing region is removed. In a similar way, a green color filter in light emitting region of the green pixel unit and a blue color filter in light emitting region of the blue pixel unit are formed respectively. A Black Matrix (BM) may be formed prior to forming the color filter. The BM may be arranged between adjacent pixel units, preventing a color mixture of the lights respectively emitted from the light emitting regions of adjacent pixel units, and suppressing light leakage. The BM may also be arranged outside the light emitting region and the light transmitting region of the pixel unit, for example, arranged in a region where the thin film transistor locates, a region where the metal wire locates.

[0075] An overcoat is arranged on the substrate provided with the thin film transistor device and the color filter, and covers the thin film transistor device and the color filter. The light transmitting region of the pixel unit may be not provided with the overcoat, so as to further increase the transmittance of the light transmitting region in the pixel unit.

[0076] The white organic light emitting device is formed on the overcoat, including forming an anode, a light emitting function film and a cathode of the white organic light emitting device. Prior to forming the white organic light emitting device, a pixel define layer may be further formed. In which, the anode may be made of a transparent conductive material with high work-function, for example, Indium Tin Oxide (ITO). The anode may be formed by methods such as sputtering, evaporation, inkjet printing. The anode electrically connects to a drain electrode of the thin film transistor, for example, the anode connects to drain electrode of the thin film transistor through a via hole of the passivation layer and a via hole of the overcoat. A light emitting function film is formed on the anode, including forming a Hole Injection Layer (HIL), a Hole Transport Layer (HTL), an Emitting Layer (EML), an Electron Transport Layer (ETL), and an Electron Injection Layer (EIL). A cathode of the white organic light emitting device is formed on the light emitting function film. In the present embodiment, the light transmitting region of the pixel unit is not provided with the cathode. A Fine Metal Mask (FMM) evaporation cathode material may be used when forming the cathode, then the light transmitting region

of the pixel unit is not provided with a cathode material layer, so that the transmittance of the light may be further increased in the light transmitting region. In the present embodiment, the light transmitting region of the pixel unit may also not provided with the anode and the light emitting function film, then the transmittance of the transmitting region may be further increased. A Fine Metal Mask may be used to form the anode and the light emitting function film.

[0077] The above are merely the preferred embodiments of the present disclosure. It should be noted that, a person skilled in the art may further make improvements and modifications without departing from the principle of the present disclosure, and these improvements and modifications shall also be considered as the scope of the present disclosure.

1. An organic light emitting diode (OLED) display panel, comprising a plurality of pixel units, wherein each of the plurality of pixel units comprises a light emitting region and a light transmitting region, the light emitting region is provided with a white organic light emitting device and a color filter;

and wherein the light transmitting region is not provided with the color filter.

2. The OLED display panel according to claim 1, wherein a cathode of the white organic light emitting device is made of an opaque material or a semiopaque material, the light transmitting region is not provided with the cathode of the white organic light emitting device.

3. The OLED display panel according to claim 1, wherein the light transmitting region is not provided with an anode and/or a light emitting function film of the white organic light emitting device.

4. The OLED display panel according to claim 1, wherein the light transmitting region is arranged on a region of the pixel unit where a thin film transistor device and a metal wire are not provided.

5. The OLED display panel according to claim 1, wherein the respective light transmitting regions in the plurality of pixel units have a same position and a same size.

6. The OLED display panel according to claim 1, wherein the respective light transmitting regions in the plurality of pixel units have a different position and a different size.

7. The OLED display panel according to claim 1, wherein the plurality of pixel units comprise a green pixel unit, a red pixel unit and a blue pixel unit, the light transmitting region of the green pixel unit has an area of T_G , the light transmitting region of the red pixel unit has an area of T_R , the light transmitting region of the blue pixel unit has an area of T_B , wherein $T_G > T_R > T_B$.

8. The OLED display panel according to claim 1, wherein the OLED display panel comprises an array substrate;

the array substrate comprises a base substrate, a thin film transistor devices and the color filter;

the thin film transistor devices and the color filter are arranged on the base substrate; and

an overcoat is arranged on the thin film transistor device and the color filter, and the white organic light emitting device is arranged on the overcoat.

9. The OLED display panel according to claim 1, wherein the OLED display panel comprises an array substrate and a packaging substrate,

the array substrate comprises a base substrate, a thin film transistor device and the white organic light emitting device;

the thin film transistor device and the white organic light emitting device are arranged on the base substrate; and the color filter is arranged on the packaging substrate at a position corresponding to the white organic light emitting device.

10. A method for manufacturing the organic light emitting diode (OLED) display panel according to claim **1**, comprising a step of:

forming the color filter and the white organic light emitting device in the light emitting region in each of the plurality of pixel units included in the OLED display panel, wherein the light transmitting region in each of the plurality of pixel units is not provided with the color filter.

11. The method according to claim **10**, further comprising a step of:

forming a cathode of the white organic light emitting device in the light emitting region in each of the plurality of pixel units, wherein the light transmitting region in each of the plurality of pixel units is not provided with the cathode.

12. The method according to claim **10**, further comprising a step of:

forming an anode, a light emitting function film and a cathode of the white organic light emitting device in the light emitting region in each of the plurality of pixel units, wherein the light transmitting region in each of the plurality of pixel units is not provided with the anode, the light emitting function film and the cathode.

13. The method according to claim **10**, further comprising a step of:

forming an anode and a light emitting function film of the white organic light emitting device in the light emitting region in each of the plurality of pixel units, wherein the light transmitting region in each of the plurality of pixel units is not provided with the anode and/or the light emitting function film.

14. The OLED display panel according to claim **2**, wherein the light transmitting region is not provided with an anode and/or a light emitting function film of the white organic light emitting device.

15. The OLED display panel according to claim **2**, wherein the light transmitting region is arranged on a region of the pixel unit where a thin film transistor device and a metal wire are not provided.

16. The OLED display panel according to claim **3**, wherein the light transmitting region is arranged on a region of the pixel unit where a thin film transistor device and a metal wire are not provided.

17. The OLED display panel according to claim **4**, wherein the light transmitting region is arranged on a region of the pixel unit where a thin film transistor device and a metal wire are not provided.

18. The OLED display panel according to claim **6**, wherein the plurality of pixel units comprise a green pixel unit, a red pixel unit and a blue pixel unit, the light transmitting region of the green pixel unit has an area of T_G , the light transmitting region of the red pixel unit has an area of T_R , the light transmitting region of the blue pixel unit has an area of T_B , wherein $T_G > T_R > T_B$.

* * * * *

专利名称(译)	OLED显示面板及其制造方法		
公开(公告)号	US20150357384A1	公开(公告)日	2015-12-10
申请号	US14/416257	申请日	2014-04-17
[标]申请(专利权)人(译)	京东方科技集团股份有限公司		
申请(专利权)人(译)	京东方科技集团股份有限公司.		
当前申请(专利权)人(译)	京东方科技集团股份有限公司.		
[标]发明人	LI YUNFEI NAGAYAMA KAZUYOSHI		
发明人	LI, YUNFEI NAGAYAMA, KAZUYOSHI		
IPC分类号	H01L27/32 H01L51/56 H01L51/52		
CPC分类号	H01L27/3216 H01L27/322 H01L2227/323 H01L27/3258 H01L51/56 H01L51/5231 H01L27/326		
优先权	201310741370.6 2013-12-27 CN		
其他公开文献	US9450029		
外部链接	Espacenet USPTO		

摘要(译)

提供了一种OLED显示面板及其制造方法。 OLED显示面板包括多个像素单元，多个像素单元中的每一个包括发光区域和透光区域，发光区域设置有白色有机发光器件和滤色器；透光区域不设置有滤色器。根据本公开的实施例，特别地在滤色器上添加透光区域，使得可以增加透射率，从而获得更好的透明显示效果而没有额外的处理，这可以仅通过适当地调整设计。

